



Purpose-Built Log Handlers

L90

Capacity

Tipping Capacity.....	@ 54" Load Center....	107,000 lbs (48,534 kg).....	99,000 lbs (44,906 kg)
Rated Capacity.....	@ 54" Load Center....	90,000 lbs (40,823 kg).....	80,000 lbs (36,287 kg)

L90

L90 High Lift

Engine (Tier III available until end of 2017)

Make and Model.....	Cummins QSX15
Max Horsepower	535 HP
<i>Optional:</i>	
Make and Model.....	Caterpillar C15
Max Horsepower	540 HP

Service Refill Capacities

Fuel Tank	200 Gal (757 liters)*
Hydraulic Oil	200 Gal (757 liters)*
Engine w/Filter.....	11 Gal (42 liters)*
Cooling System	22.5 Gal (85 liters)*

Torque Converter

Dana 9000 Series with Pump Drives

Transmission

Dana 8000 Series with 4 Speeds Fwd and Rev

Axles

Front Axle Planetary Final Reduction

Tires

Single Drive Tires	Standard
Front	(2) 37.25 x 35
Rear	(2) 23.5 x 25
Dual Drive Tires	Optional
Front	(4) 24.00 x 35
Rear	(2) 23.5 x 25
Biased Ply Tire Construction	Standard
Radial Tire Construction	Optional

Cab

Best in class working environment includes the following:

Noise (dBa) Inside Cab (ISO 6396:2008).....	72 dB
Visibility.....	360°
Convex Front Windshield	Standard
Falling Objects Protection (F.O.P.) Certification.....	Standard
Heat/AC	Standard
Air Seat Suspension for Operator Comfort.....	Standard
Cab Isolation from Chassis (Noise/Vibration Reduction).....	Standard
Rotating Platform, 90°	Standard
Sliding Windows	Optional
Load Dampening	Optional
Joystick Steering	Optional

Features & Options

Wet Disc Brakes	Standard
Remote Engine Oil Drain.....	Standard
Stairwell Access.....	Standard
Central Lube	Standard
Sight Gauges.....	Standard
Service Bay	Standard
ANSUL Fire Suppression (Liquid)	Standard
LED Lights.....	Standard
Tilt Cab	Optional
HID Lights.....	Optional
Front and Rear Cameras.....	Optional
Warning Beacon	Optional
Converter Lockup	Optional

* Approximate

L90

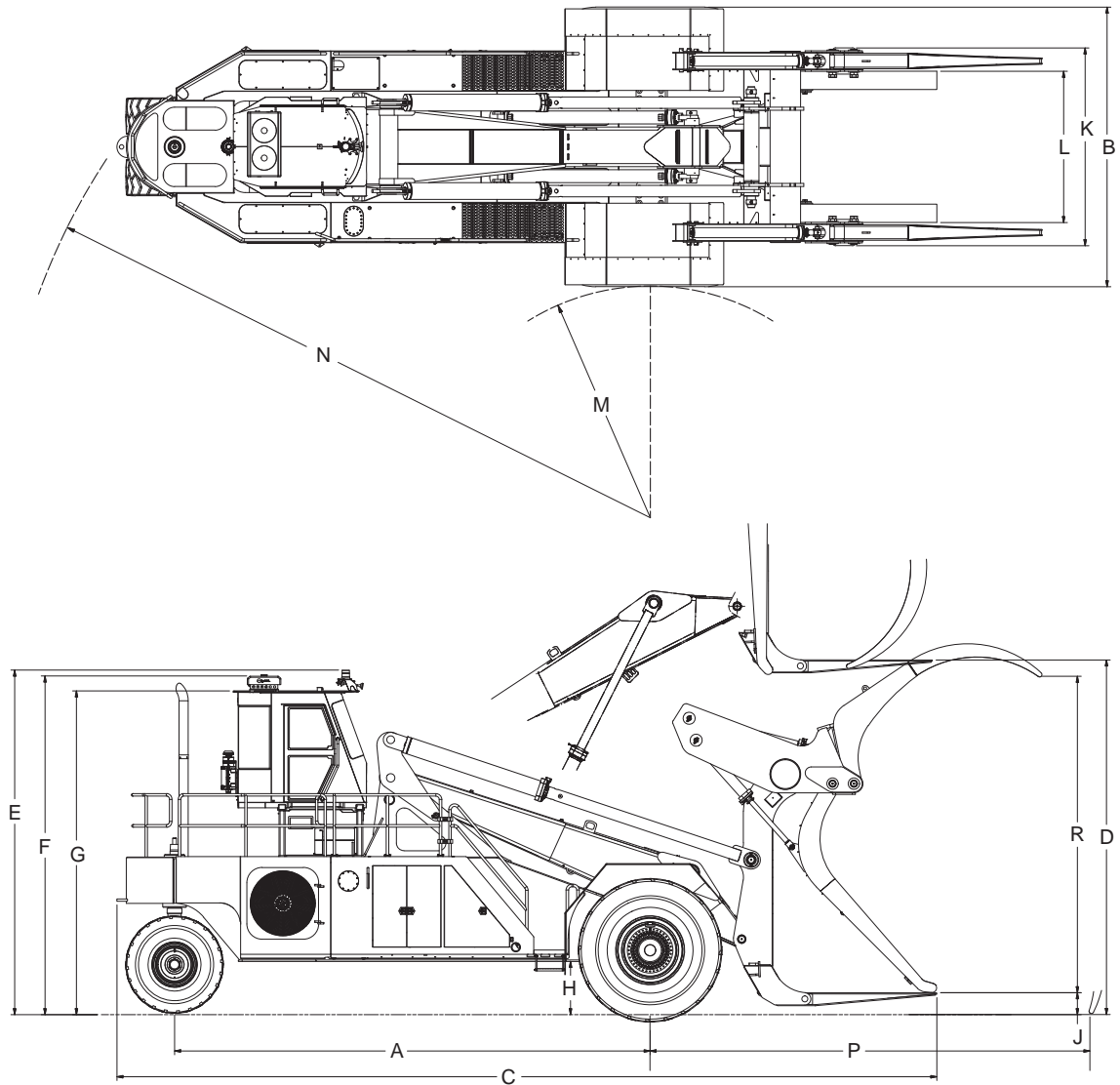

Dimensions*

	L90	L90 High Lift
A. Wheelbase	26' 0" (7,925 mm)	26' 0" (7,925 mm)
B. Width	15' 3" (4,659 mm)	15' 3" (4,659 mm)
C. Length	44' 10" (13,662 mm)	46' 7" (14,192 mm)
D. Lift Height	19' 5" (5,907 mm)	22' 7" (6,885 mm)
E. Cab Height (highest point)	18' 10" (5,741 mm)	18' 10" (5,741 mm)
F. Cab Height w/AC	18' 6" (5,643 mm)	18' 6" (5,643 mm)
G. Cab Height	17' 8" (5,394 mm)	17' 8" (5,394 mm)
H. Ground Clearance Chassis	2' 11" (889 mm)	2' 11" (889 mm)
J. Ground to Front Tip of Tine	1' 2" (366 mm)	1' 2" (366 mm)
K. Carriage Width	10' 10" (3,296 mm)	10' 10" (3,296 mm)
L. Width Across Tines	8' 3" (2,521 mm)	8' 3" (2,521 mm)
M. Inside Turning Radius	12' 8" (3,862 mm)	12' 8" (3,862 mm)
N. Swing Radius	35' 7" (10,855 mm)	35' 7" (10,855 mm)
P. Distance from Axle to Holddown Tip for Reach	24' 1" (7,330 mm)	26' 9" (8,153 mm)
R. Mouth Opening	17' 4" (5,272 mm)	17' 4" (5,272 mm)

Weights*

Unit Weight (Empty)	135,000 lbs (61,235 kg)
Unit Weight (Loaded)	225,000 lbs (102,058 kg)

Hoist Speed

66% of Rated Load	9.1 Seconds (2 ft/second)
100% of Rated Load	18.2 Seconds (1 ft/second)

Speed (Unladen)

1	4.4 mph (7.1 km/h)
2	7.6 mph (12.2 km/h)
3	12.7 mph (20.4 km/h)
4	22.4 mph (36.0 km/h)

Custom carriage options are also available

*Approximate



wagner

A Division of Allied Systems Company

21433 S.W. Oregon Street
Sherwood, Oregon 97140 USA
Telephone: 503.625.2560 • Fax: 503.625.7980
E-mail: wagner@alliedsystems.com
www.alliedsystems.com