

EXPLOSION PROOF

Diesel Engines For Hazardous Areas

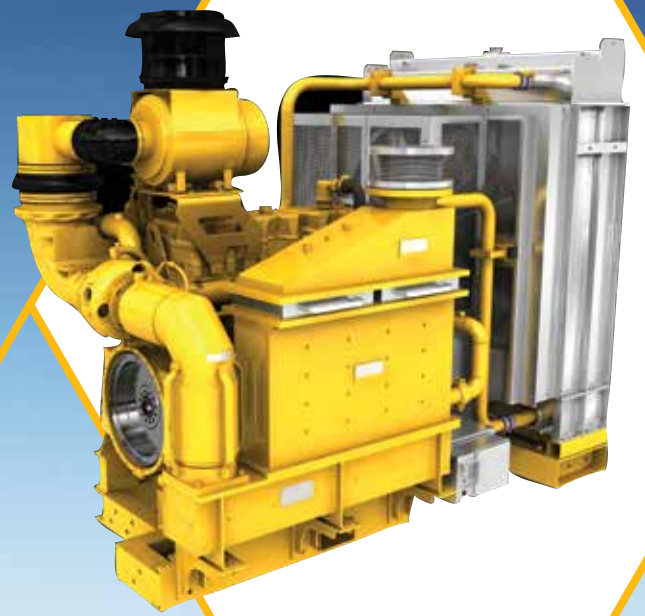

HAZARDOUS AREAS

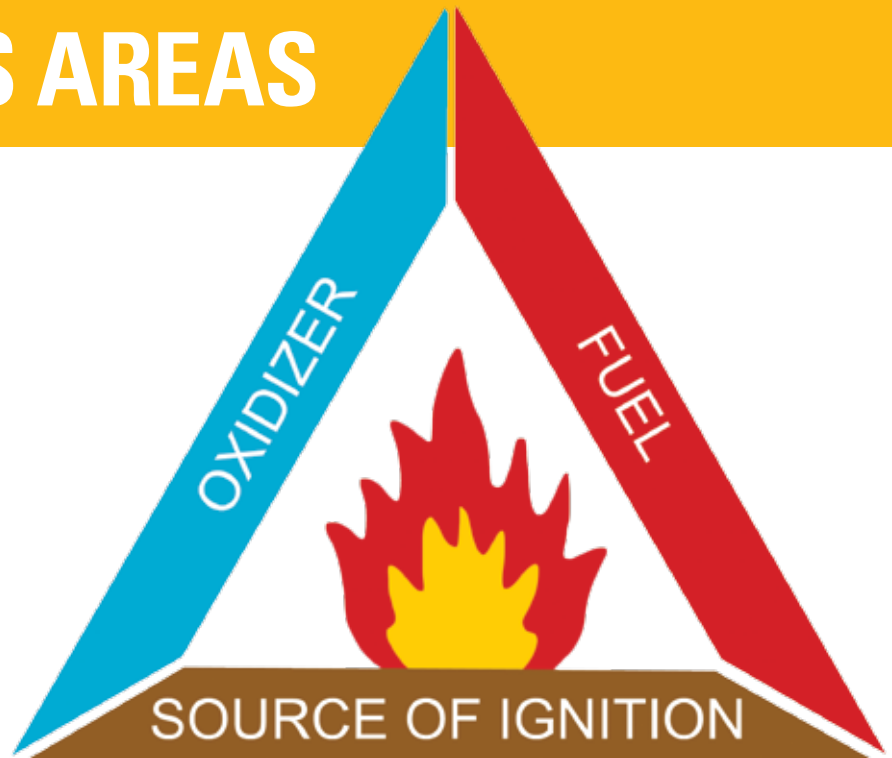

Managing the Risk

There is always a risk of a flammable hydrocarbon release in the oil and gas industry. When the release comes into contact with air and an ignition source, an explosion can happen.

Cat HazPak solutions are designed to help keep these elements apart.

When the job takes you into a hazardous location, Cat® HazPak engines are ready.

Our complete range of services and engine packages cover both industry standards and your operation with maximum safety.

The Science of Explosions

Safety is only effectively achieved through a holistic approach to explosion protection.

All factors must be considered in conjunction as illustrated here – it only takes one weak link to cause an explosion.



Diesel Engines in Hazardous Areas

Potential ignition sources on unprotected diesel engines include electrical, mechanical, or static sparks, overspeed or flame from inlet or exhaust, and hot surfaces.

Flammable gases in the atmosphere can be sucked in through the air intake along with air for combustion. This can result in flashbacks through the inlet, backfires in the exhaust, or engine overspeed.

If the engine consumes flammable gas mixed with air and diesel fuel, engine overspeed can occur, which can lead to the engine running out of control. This can result in catastrophic failure of the engine.

Another risk is engine misfiring, leading to an explosion further down the exhaust system, which could then ignite the surrounding atmosphere.

Various surfaces on a diesel engine can become hot and therefore sources of ignition. These surfaces need to be protected to avoid the danger of explosion.

Cat explosion-protection technology was developed to guard against these and many other dangers.

Engine Design

A typical Cat HazPak engine includes features to prevent an ignition source causing the event of a hydrocarbon release.

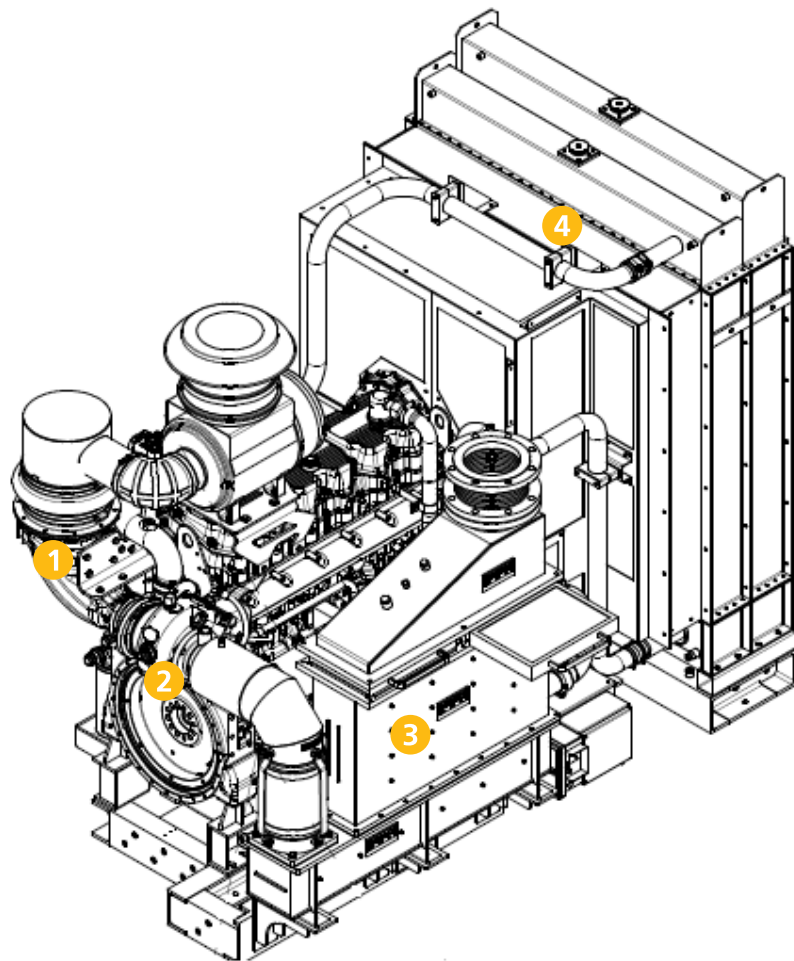

KEY

- 1 Air Inlet Flame Arrester with Shut-off**
Provides shutdown on overspeed
- 2 Water-cooled Turbocharger and Exhaust Manifold**
Ensures surface temperature is below 200°C (T3)
- 3 Exhaust Gas Heat Exchanger**
Cools the engine exhaust below 200°C (T3)
- 4 Radiator**
The solder-dipped radiator core provides additional cooling capacity

Explosion protection also includes:

- Battery and electrics
- Charge air pipe
- Automated shut-off system
- ECM

EXPLOSION PROOF RANGE

C2.2 NA

HazPak

Fixed Speed:

19 bkW/27 bhp @ 1500 rpm

24 bkW 31 bhp @ 1800 rpm

Variable Speed:

31 bkW/ 41 bhp @ 2200 rpm



C4.4 NA

HazPak

Fixed Speed:

43 bkW/57 bhp @ 1500 rpm

49 bkW/65 bhp @ 1800 rpm

Variable Speed:

55 bkW/74 bhp @ 2200 rpm



C4.4 TA

HazPak

Fixed Speed:

97 bkW/130 bhp @ 1500 rpm

112 bkW /151 bhp @ 1800 rpm

Variable Speed:

97 bkW/130 bhp @ 2200 rpm



C7

HazPak (with fan)

158 bkW/211 bhp @ 2200 rpm

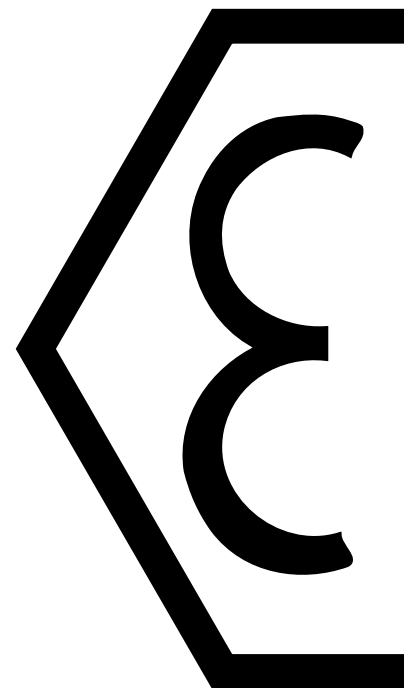
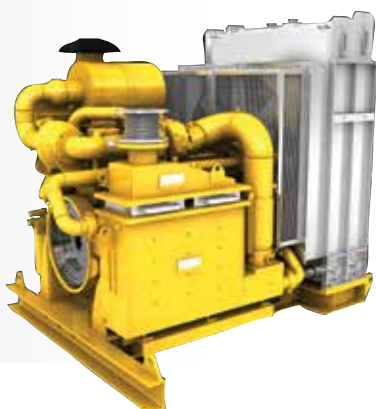

All Cat HazPak products are certified for hazardous location use, with some having tri-certification to ATEX 94/9/EC, IECEx and NEC 505/NEC 500.

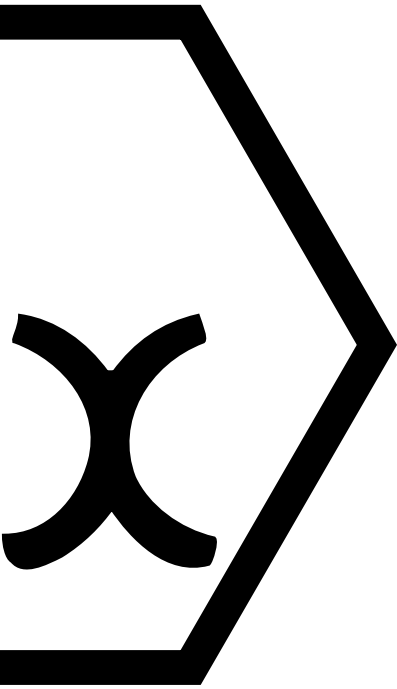

C9
HazPak (with fan)
227 bkW/304 bhp @ 2200 rpm

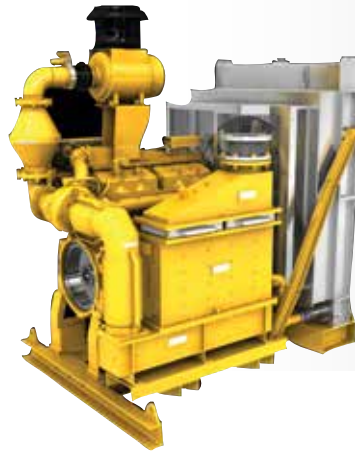

3406C
HazPak (without fan)
365 bkW/490 bhp @ 2100 rpm

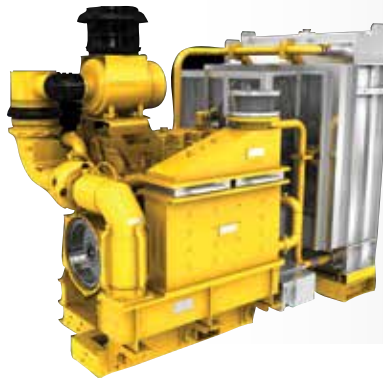

C15
HazPak (with fan)
376 bkW/504 bhp @ 1800-2000 rpm



C18
HazPak (without fan)
533 bkW/715 bhp @ 2100 rpm

The engine images are indicative of a standard engine package, with a standard spark arrester. Options are available on these packages, please contact your Cat representative for more information.

POWER AND COMPLIANCE



Certification and Testing

All Cat HazPak engines are certified, with some having tri-certification to ATEX 94/9/EC, IECEx, and NEC 505/NEC 500.

With in-house test facility procedures and approval to national standards, Caterpillar ensures quality at every step in the process

Quality

Additional to ISO9001:2008 quality standard certification, Caterpillar has the required level of third party certification for ATEX, IECEx, and NEC.



Cat HazPak engines are designed, tested, and certified to support the certification of your completed equipment. All products are supported in the field by specialist engineers.

Engineering Excellence

With more than 40 years of experience delivering complex hazardous area engineering solutions, Caterpillar delivers high quality safety products worldwide.



Manufacturing Security

Cat HazPak engines are designed, manufactured, and tested by Caterpillar, in Caterpillar factories for single-source package confidence.





Legal Compliance

Regional legislation governs health and safety issues related to explosion protection of electrical equipment worldwide.

However, since mechanical equipment is not always regulated, there is a significant potential risk to people, the environment, and your investment. Be aware of the risks and choose additional discretionary safety.

Electrical Equipment

Europe	USA	Rest of World
ATEX 94/9/EC	NEC	IECEX

Mechanical Equipment

Europe	USA	Rest of World
ATEX 94/9/EC	-	Regional specific

Global Support

Cat Zone 2 hazardous location solutions are fully supported by the Cat worldwide dealer network.

More than 100,000 trained technicians and global parts distribution ensure that the parts and support you need are never out of reach.

Engineers can be quickly mobilized offshore with all the necessary medical certificates and survival training, anywhere in the world 24/7/365.





One-source Confidence

Cat HazPak engines are designed, tested, and certified to support the certification of your completed equipment. And the Cat dealer network is ready with the Cat parts, maintenance, and repair you need for the life of your engine. We're built to keep your operation safe.

To learn more about offshore power from Caterpillar Oil & Gas, call your local Cat dealer or visit www.catoilandgasinfo.com.

BUILT FOR IT.™

Caterpillar Oil & Gas

AMERICAS

Caterpillar Inc.
Oil & Gas
13105 N.W. Freeway
Suite 1100
Houston, Texas 77040-6321
Tel: (+1) 713-329-2207
Fax: (+1) 713-895-4280

RUSSIA

Caterpillar Eurasia
82 Sadovnicheskaya Str.
Moscow 115035
Tel: (+7-495) 213-3340
Fax: (+7-495) 213-3372

ASIA PACIFIC

Caterpillar Asia Pte., Ltd.
Oil & Gas
7 Tractor Road
Singapore 627968
Tel: (+65) 6828-7333
Fax: (+65) 6828-7414

CHINA

Caterpillar Oil & Gas China
Room 1601 Caterpillar Tower
No. 8 Wangjing Street
Beijing 100102, P.R. China
Tel: (+86-10) 5921-0521
Fax: (+86-10) 5921-0022

EUROPE, AFRICA, AND MIDDLE EAST

Caterpillar Commercial Northern Europe Ltd.
Oil & Gas
OTV House
Wokingham Road, Rounds Hill
Bracknell, Berkshire
United Kingdom
RG42 1NG
Tel: (+44) 1344 782 920
Mobile: (+44) 7717411938
Fax: (+44) 1344 782 930

Caterpillar Motoren GmbH & Co. KG

Oil & Gas
Falckensteiner Str. 2
D-24159 Kiel, Germany
Tel: (+49) 431 3995 3004
Fax: (+49) 431 3995 5004